

S-3600T Power Unit with DC-1250 Dirt Canister

The Silent Partner® S-3600T is a specially designed split canister system that allows for 2-user operation when paired with the DC1250 dirt can and special installation. This two part system includes the motors, which is housed in a special foam-lined chamber that reduces motor noise coming from the unit power unit and a separate dirt canister, used for dirt collection and filtration. The split system allows you to hang the dirt canister in an easy-to-service area of your home, while locating the motor unit away from the living environment, such as a garage or basement. The S-3600T uses cyclonic filtration. Once dirt and debris is swept up, it goes into the dirt canister where it swirls around, separating the large debris from the small, allowing the large debris to fall to the bottom of the dirt can while the lighter dirt and dust is vented straight outside of your home. The 14" diameter dirt canister, designed especially for our high airwatt motors, has improved filtration, now as much as 98% efficiency. With Vacu-Maid's patented Air Channel, you eliminate clouds of dust billowing up in your face when you empty the dirt can. The S-3600T is constructed from rolled galvanized steel and powder coated for a tough, corrosion-resistant lifetime of use. As with all of our Vacu-Maid central vacuum systems, using the S-3600T can help decrease asthma and allergy symptoms by removing dust and allergens from your living areas.



SilentPartner®

S-3600T Split Canister System

MOTORS	(2) Premier 7.2" Tangential By-Pass
VOLTAGE	240 A.C.
MAX AMPS	16.4
MAX AIR WATTS	1268
AIRFLOW (CFM)	229
SEALED VACUUM (inches H ₂ O)	137
FILTRATION	Cyclonic
SOUND LEVEL	74 db
UP TO TOTAL SQ. FEET	18,000 +
DIRT CAPACITY	38 Qt.

Features & Benefits:

- Special design and installation, allows this machine to accommodate 2 users.
- Cyclonic Filtration--Filter free cyclonic separation; no messy bags or filters.
- Patented Air Channel--Allows a plastic can liner to be used inside the dirt canister making emptying the can less hassle and less mess.
- 14" Dirt Canister--Larger dirt capacity equals less emptying of the dirt can.
- Improved Filtration--98% filtration.

S-3600T Power Unit with DC-1250 Dirt Canister

With special design, the Silent Partner® S-3600T can accommodate 2-users when used with the special DC1250 dirt canister. The designation for a two user system will be S3600T and will include a DC1250 Dirt Canister.

The two user system requires careful engineering and oversized pipe.

The new DC1250 has a 2" Schedule 40 opening so that the intake pipes do not need to be sized down.

S3600T's are Special Order Only. Please contact your sales representative, Jim or Jeff to begin the process of designing and ordering this unique and one-of-a-kind machine.

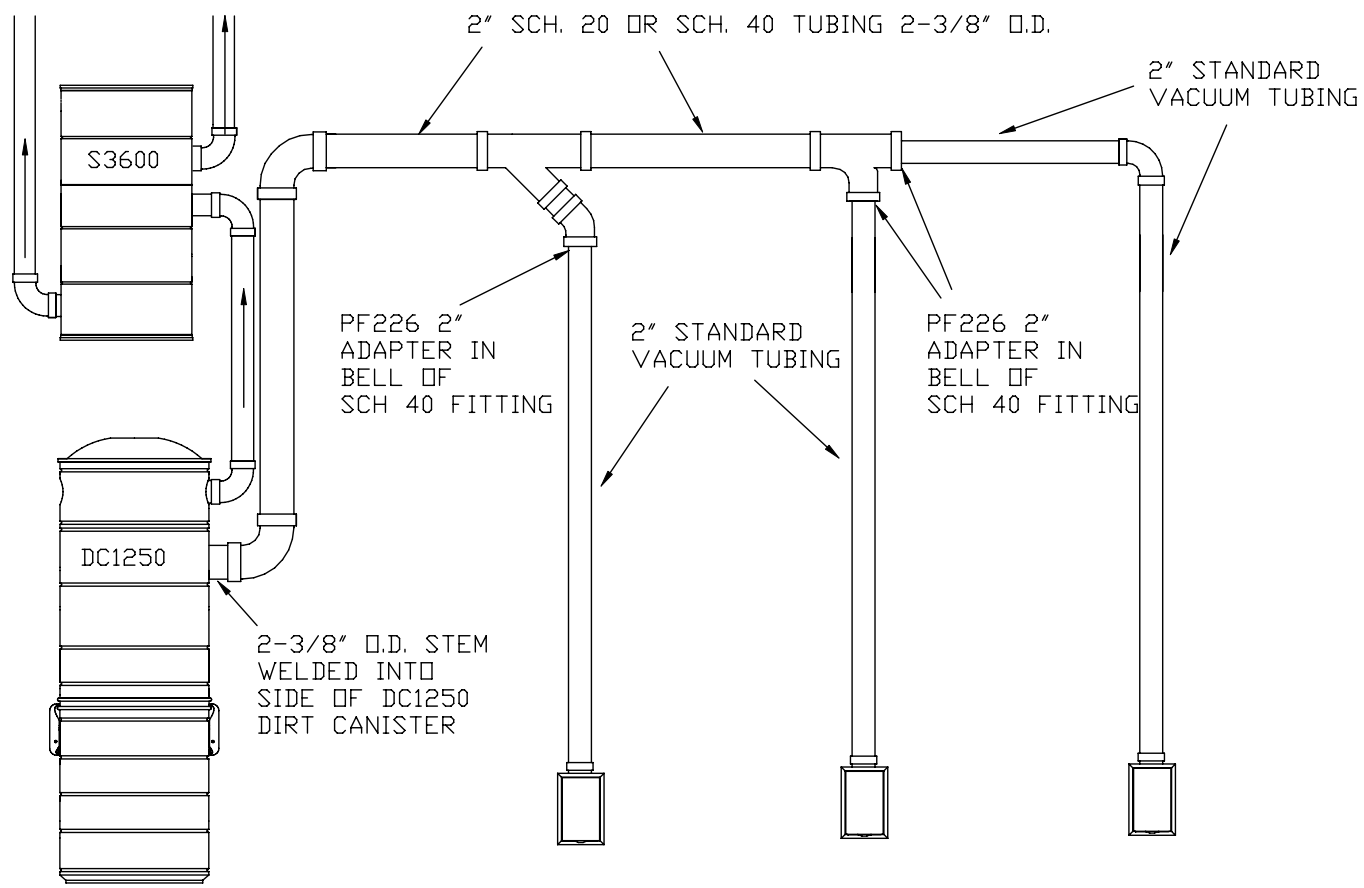

TYPICAL INSTALLATION OF THE S3600 WITH DC1250
(THIS IS A TWO USER SYSTEM)